

FORCE TORQUE SENSOR

FT 150

**A 6-AXIS FORCE TORQUE SENSOR
EASY TO INTEGRATE AND IMMUNE
TO EXTERNAL ELECTRICAL NOISE**



HIGH QUALITY SIGNAL

- Immune to external electrical noise
- No filtering needed

DIRECT COMMUNICATION WITH YOUR ROBOT CONTROLLER

- No need for an external signal processing box

SPEED UP INTEGRATION

- Compatible with industrial robots
- Software packages available for Universal Robots, ROS, Linux and Windows

DESIGNED FOR

ASSEMBLY



HAND GUIDING

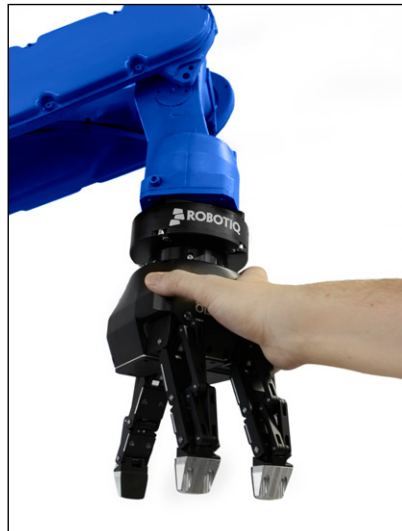

FINISHING



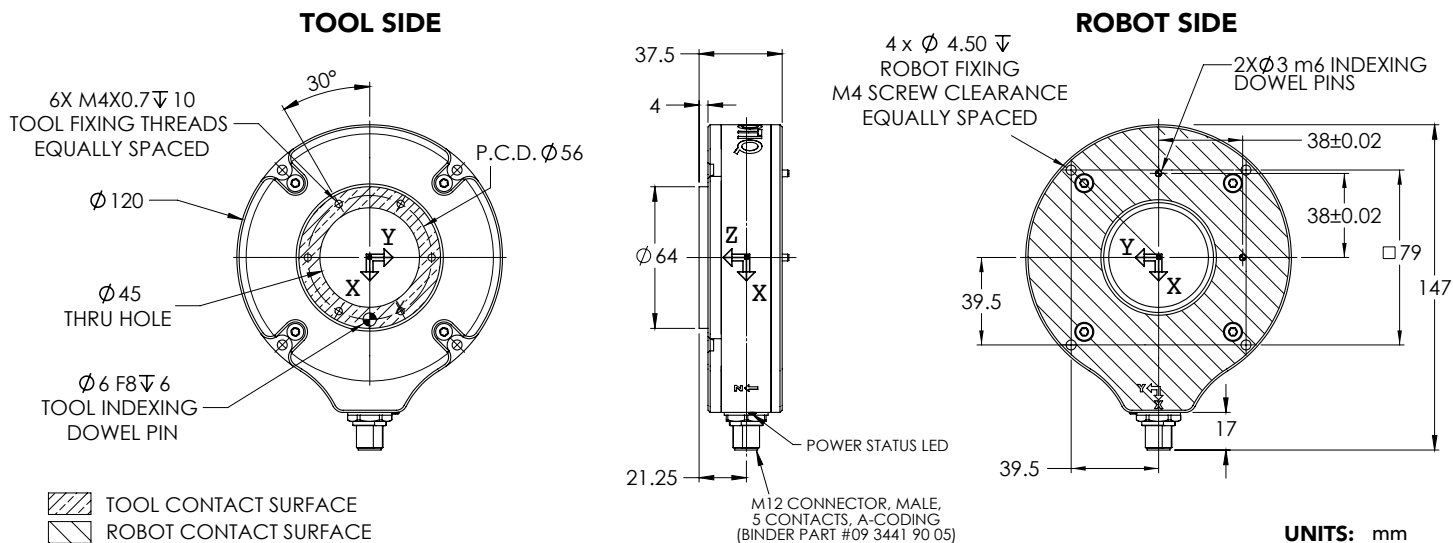

SIGNAL SPECIFICATIONS

Measuring range	Fx, Fy, Fz	± 150 N	
	Mx, My, Mz	± 15 N·m	
Effective resolution	Fx, Fy, Fz	0.2 N	
	Mx, My, Mz	0.02 N·m	
Signal noise	Fx, Fy, Fz (combined)	0.5 N	Noise is here defined as the standard deviation of all data collected for 10 seconds for a steady signal. The value is computed for all 3 sensing elements for both vectors.
	Mx, My, Mz (combined)	0.03 N·m	
External noise sensitivity	All axes	Immune	For example, welding current passing through the sensor hole does not affect the readings.
Cross-talking	All axes	None	The sensing elements are aligned with the measurement axes, such that they are not affected by effort in other axes.
Drift	Fx, Fy, Fz	± 3 N over days	Hour-to-hour drift is non-significant. Can be minimized if the environment is well-controlled.
	Mx, My, Mz	Non-significant	
Data output rate		100 Hz	
Temperature compensation		15°C - 35°C	Temperature fluctuation is compensated for within this range. Signal quality may be affected outside of this range.

MECHANICAL SPECIFICATIONS

Outside diameter		120 mm	
Through-hole diameter		45 mm	
Thickness		37.5 mm	Without adapter plate.
Weight		650 g	
IP rating		IP54	
Stiffness (calculated)	Fx, Fy	3.2×10^6 N/m	
	Fz	3.9×10^6 N/m	
	Mx, My	4700 N·m/rad	
	Mz	4600 N·m/rad	
Mechanical overload	All axes	5x max measurement	

ELECTRICAL SPECIFICATIONS

Input voltage		6-28 VDC	
Max power consumption		2 W	
Sensor electrical interface		RS-485, RS-232, USB	Software packages available for Universal Robots, ROS, Linux and Windows.